

Resilient Wheel Re-Tire Press®

Customized to Meet the Needs of Any Transit Authority

The PMC Resilient Wheel Re-Tire Press is designed for the assembly of a tire and resilient blocks to a wheel center. The process of re-tiring involves gradual compression of the rubber blocks. As the wheel center passes over the blocks, the compression is partially relieved as the blocks seat into the rim of the wheel center.

After assembly, the radial and axial runout of the tire and center should be verified in accordance with car builder specifications. In addition, the shunt resistance between tire and center should be tested and recorded.

PMC Resilient Wheel Re-Tire Press Units are completely assembled and tested prior to shipping. Unit testing includes operational verification of all mechanical, electrical and hydraulic systems. High pressure hydraulic components have also been subjected to hydrostatic testing and certification by a qualified partner.

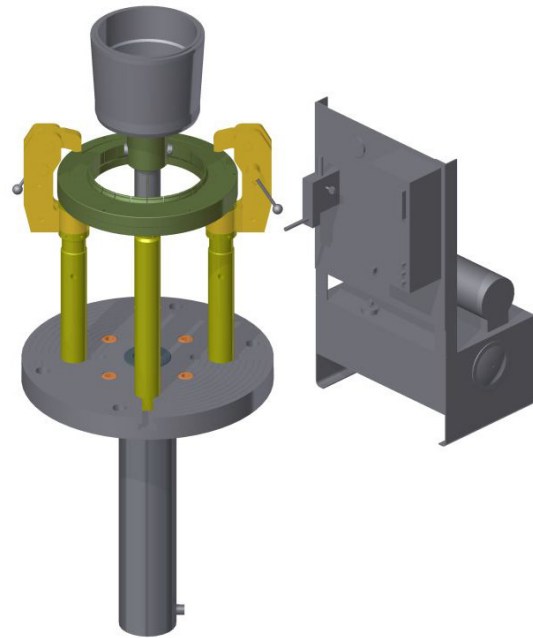

General Arrangement Drawing

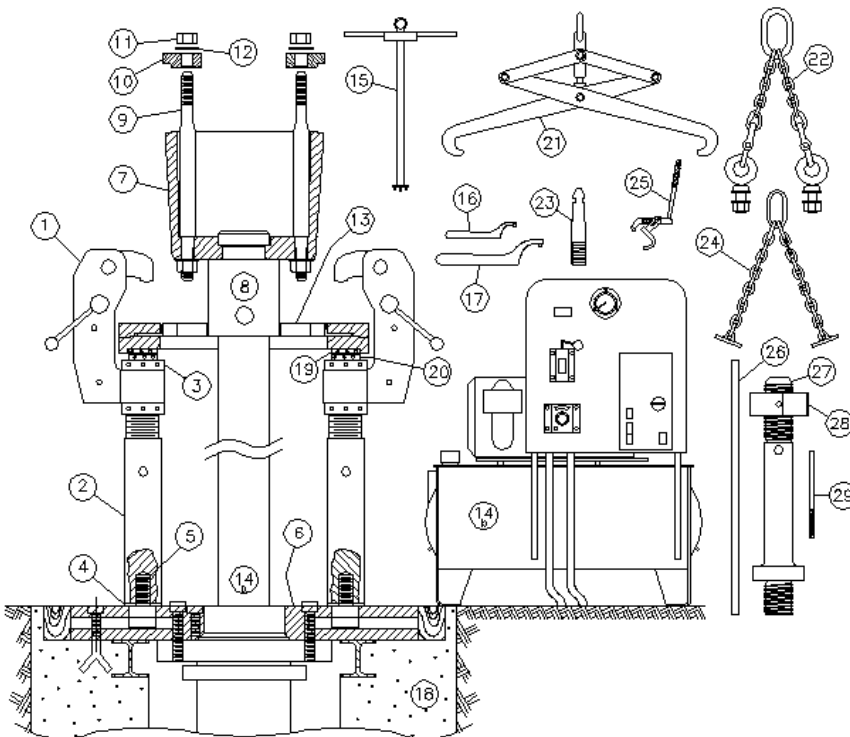

COMPONENTS <Quantity>

- 1) Clamping Hook Sub-Assembly <2>
- 2) Pillar (Clamped/Straight) <2/2>
- 3) Clamp Adjusting Ring <8>
- 4) Pillar Base Washer <4>
- 5) Pillar Bolt <4>
- 6) Base Plate <1>
- 7) Cone Assembly <1>
- 8) Cone Bearing Sub-Assembly <1>
- 9) Clamp Bolt <2>
- 10) Clamp Plate <2>
- 11) Clamp Hex Nut <2>
- 12) Clamp Washer <4>
- 13) Segmental Ring Assembly <1>
- 14) Hydraulic Unit Sub-Assembly <1>
- 15) Special Spanner <1>
- 16) Spanner Wrench - 4" <2>
- 17) Spanner Wrench - 6" <2>
- 18) Foundation (by others) <1>
- 19) Leveling Bolt <4>
- 20) Leveling Bolt Lock Ring <4>
- 21) Tire Lifting Device <1>
- 22) Wheel Set Lifting Assembly <1>
- 23) Hydraulic Cylinder Positioning Rod <2>
- 24) T-Chain Wheel Lifting Sling <1>
- 25) Not applicable
- 26) Center Post Tightening Bar <1>
- 27) Center Post <1>
- 28) Center Post Locking Ring <1>
- 29) Lock Ring Operation Rod <1>

Technical Specifications

Motor

Power Output = 10 hp [7.5 KW] @ 1745 rpm
Voltage = 230/460 V 3-Phase
Frequency = 60 Hz

Pump

Maximum Operating Pressure = 2600 psi [180 bar]
Maximum Working Pressure = 2200 psi [152 bar]
Actual Working Pressure = 1800 psi [124 bar]
Inlet Pressure = 5 in. Hg. [.17 bar] vacuum

Cylinder

Stroke = 38 in. [965.2 mm]
Bore = 10 in. [254mm] dia.
Rod = 5 in. [127 mm] dia.
Speed (approx.); Extend = 17 in/min. [432 mm/min.]
Retract = 0-28 in/min. [0-711 mm/min.]
Maximum Tested Pressure = 3000 psi [207 bar]

Hydraulic Fluid

AW 46 or ISO VG 460 with anti-wear & anti-foam additives
(CITGO, Drydene Paradene, etc. supplied by customer)
160 quarts (40 gallons) [151.5 liters] capacity

Lubricant (for Rubber Blocks)

PMC #00702045 or #00702059

Weights (Approx.)

Power Unit (Dry) = 550 lbs. [250 kg]
Hydraulic Cylinder (Dry) = 2335 lbs. [1059 kg]
Base Plate = 2120 lbs. [962 kg]
Cone Assembly = 528 lbs. [240 kg]
Segmental Ring Assembly = 567 lbs. [257 kg]
Complete Press Unit = 14,000 lbs. [6350 kg]

Replacement Parts

Hydraulic Cylinder Repair Kit – PMC #00706665
Hydraulic Cylinder Seal Kit – PMC #00706666
Hydraulic Filler/Breather 40mm – PMC #00706667
Strainer, ESA31N10AMF -- 90 Mesh – PMC #00706591
Filter Element ERA32NFC – PMC #00706668
Hose, Hydraulic Upstroke – PMC #00706466
Hose, Hydraulic Downstroke – PMC #00706467

Test Equipment

Milliohmeter
Dial Indicator
Depth Gauge

Recommended Spare Parts

Filter Element ERA32NFC – PMC #00706668

Terms & Conditions: Equipment available only to end users of PMC resilient wheel products.

A Leader in Wheels & Maintenance Equipment for Transit, Rail & Mining/Industrial Applications

In 1920, Penn Machine Company (PMC) began as a coal company and pioneered the manufacture of quality replacement parts for coal mining equipment. Over the years, the company has grown to become a major supplier of heavy-duty OEM and aftermarket components for transit, railroad, mining, steel, construction, and general industrial applications. Our business is domestic and international in scope. Our capabilities and experience combine to provide a wide range of quality manufactured products and services. Penn Machine is comprised of three market-focused stand-alone business units: Transit, Locomotive, and Industrial/Mining, with operations in Johnstown and Blairsville, PA. Penn Machine Company is part of Marmon Holdings, Inc., a global organization of manufacturers owned by Berkshire Hathaway Inc.



PENN MACHINE COMPANY

310 Innovation Drive • Blairsville, PA 15717 • 724.459.0302



A Marmon/Berkshire Hathaway Company