



PENN MACHINE COMPANY LLC

THE LEADER IN WHEEL SET SOLUTIONS

## Penn Resilient Wheels-Penn 2000

Penn Machine Company is a major supplier of solid and resilient wheels. Included in our product line are solid wheels, the original PCC resilient and super-resilient wheels, and Penn Super Cushion wheels.

### Advantages of Resilient Wheels

- Improved ride quality
- Noise reduction
- Reduced unsprung mass
- Tire and track wear reduced
- Only tire and rubber blocks require replacement at end of lifecycle
- Reduces ground-borne vibration

### Design/Construction Features

All Penn Machine resilient wheels have an elastic layer between the steel tire and wheel center. This elastic layer is comprised of a number of individual rubber or ring elements with precisely matched elasticity and damping properties. These wheels have the required conductive continuity through the independently rotating wheels to axle shaft via external current conductors. This divided wheel body facilitates dismantling and refitting of the wheel tire, and can be performed under the vehicle in the appropriate installation situation.





PENN MACHINE COMPANY LLC

THE LEADER IN WHEEL SET SOLUTIONS



### Why Penn 2000 Wheels?

- Tires can be changed without removing wheel set from truck (inboard bearing design)
- Tires can be changed with axle in horizontal position
- Less cost to change tires
- Firmer lateral direction
- Will permit heavier wheel load
- Can be custom designed for wheels 20-inch diameter or larger
- Tire changing equipment is portable, resulting in less capital investment

### Technical Data:

- Radial Spring Rate: 1,140,000 lbs/inch (200 kN/mm)
- Axial Spring Rate: 114,000 lbs/inch (20 kN/mm)
- Deflection at 5-Ton Wheel Load: 0.009-inch (0.23 mm)
- Torque Carrying Capability: > 22,000 ft-lbs (30 kN-m)
- Customized for Your Application

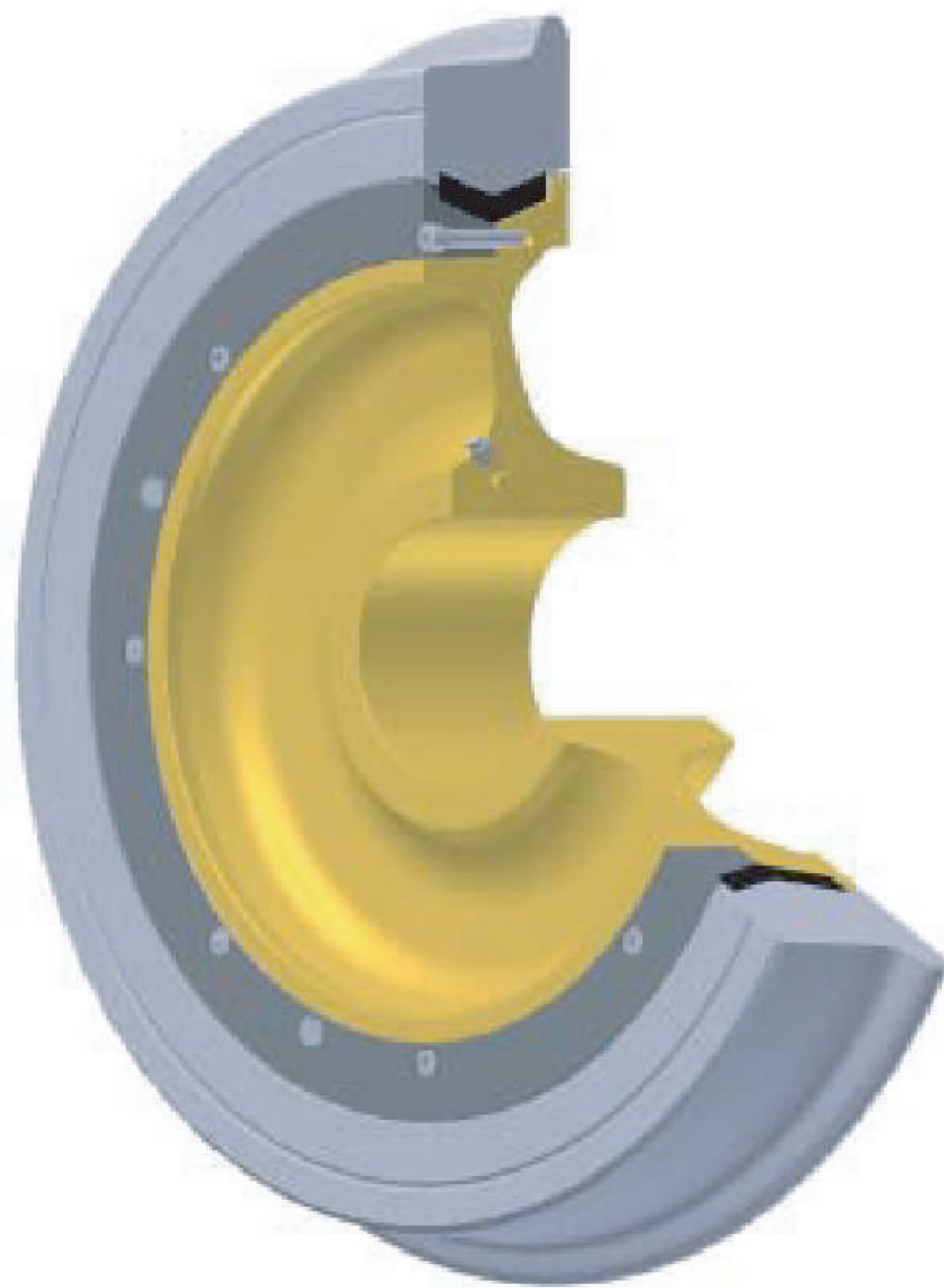
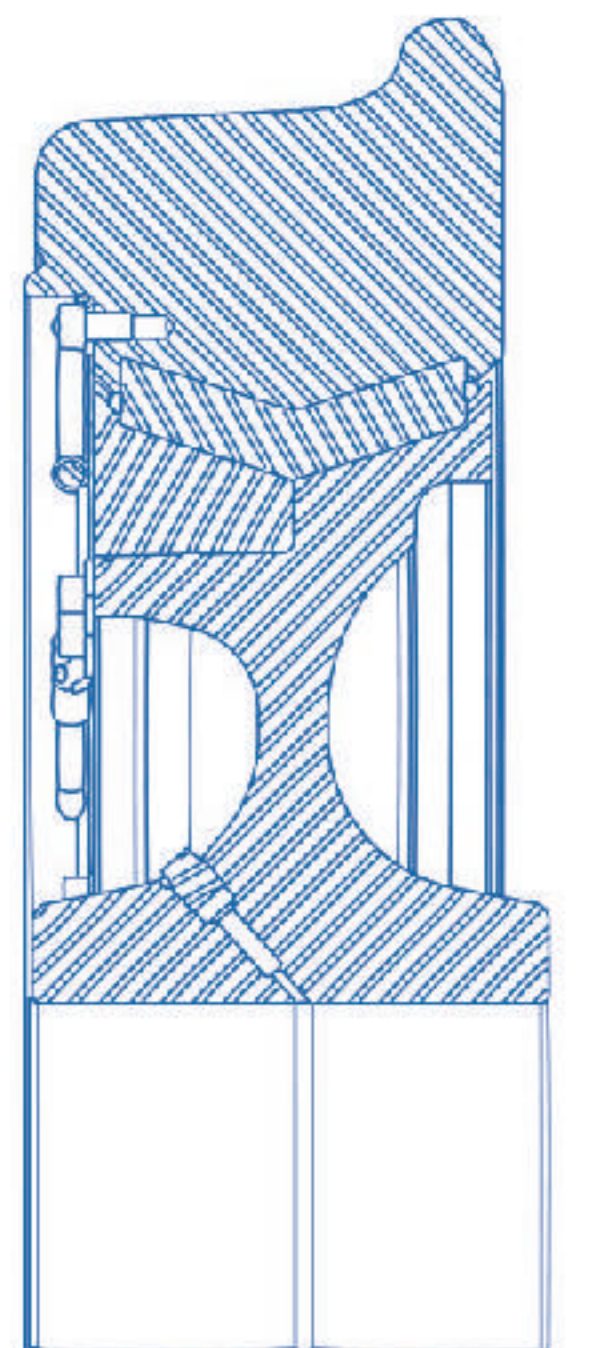

**Penn Machine Company has more than 300,000 resilient wheels in service worldwide.**

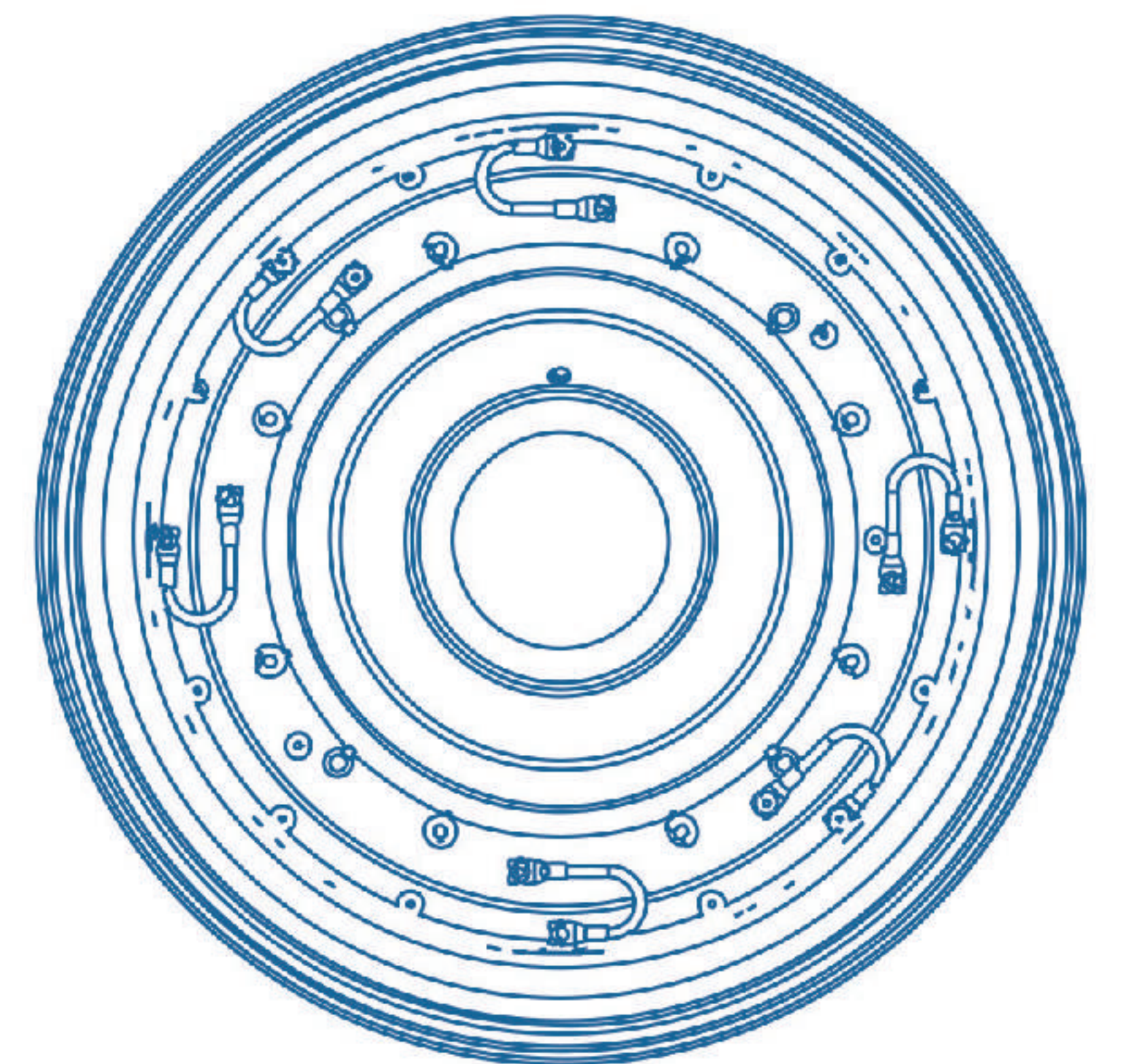

### A Leader in Wheels & Maintenance Equipment for Transit, Rail & Mining/Industrial Applications

In 1920, Penn Machine Company (PMC) began as a coal company and pioneered the manufacture of quality replacement parts for coal mining equipment. Over the years, the company has grown to become a major supplier of heavy-duty OEM and aftermarket components for transit, railroad, mining, steel, construction, and general industrial applications. Our business is domestic and international in scope. Our capabilities and experience combine to provide a wide range of quality manufactured products and services. Penn Machine is comprised of three market-focused stand-alone business units: Energy, Transit, Locomotive, and Industrial/Mining. The company has operations in Johnstown and Blairsville, PA, and is part of The Marmon Group, global organization of manufacturers owned by Berkshire Hathaway Corp.



AAR M1003



American Gear Manufacturers Association



Quality System Registrar



PENN MACHINE COMPANY LLC

Headquarters

310 Innovation Drive  
Johnstown, PA 15905

106 Station Street  
Blairsville, PA 15717



A Marmon | Berkshire Hathaway Company