



PENN MACHINE COMPANY LLC

THE LEADER IN WHEEL SET SOLUTIONS

Keep Your Historic Streetcars Up-to-Date

For more than 80 years, historic streetcars, as well as Presidents' Conference Committee (PCC) Streetcars, have been used by municipal transit authorities in hundreds of North American cities. These onetime workhorses for moving people around town remain operational in San Francisco, Philadelphia, San Diego, Toronto and elsewhere. The one thing all of these cars have in common is that they rely on Penn Machine's engineering and mechanical expertise to remain in operation.

To make sure your historic trolleys and PCC Streetcars remain in top working order, depend on us for resilient wheel designs and complete wheel set repair. We have been the OEM since 1936.

At Penn Machine, we're proud to be North America's largest supplier of wheels for historic trolleys and PCC Streetcars.

Then

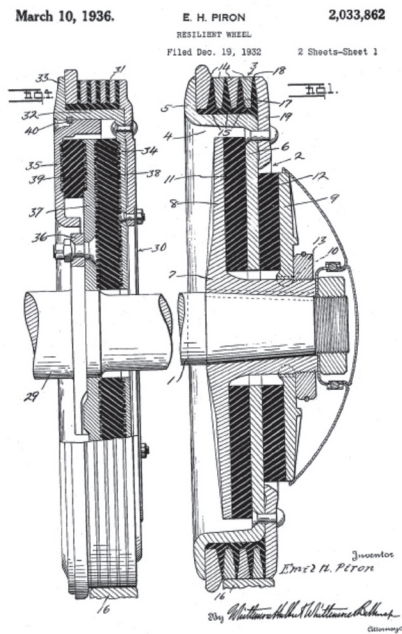

Now

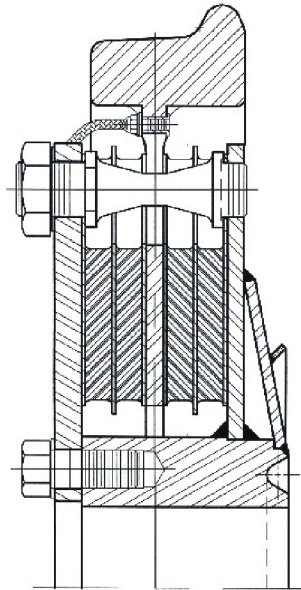



PENN MACHINE COMPANY LLC

THE LEADER IN WHEEL SET SOLUTIONS

PCC Streetcars: A Timeline

- 1920s** – Streetcar ridership declines due to increased use of relatively comfortable automobiles.
- 1929** – Presidents’ Conference Committee (PCC) formed.
- 1931** – PCC renames itself the **Electric Railway Presidents’ Conference Committee (ERPCC)**.
- 1934** – First PCC streetcar prototypes ready for testing.
- 1936** – First PCC streetcars placed into service in Brooklyn.
Series of patents related to truck design, propulsion and use of rubber in springs and other components reduce noise and improve ride quality.
- 1952** – Westinghouse develops improved acceleration & braking system.
Last PCC streetcars built for a North American system, the San Francisco Municipal Railway (Muni).
- 1953** – Transit authorities throughout North America begin purchasing used PCC streetcars.
- 1995** – San Francisco Muni re-opens the F Market Line (historic street car service).
- 2017** – Toronto Transit Authority operating two PCC streetcar for private charter.
Chicago Transit Authority operates a single PCC streetcar, the only one remaining from the 683 it purchased from 1936-48.
Philadelphia Transportation Company owns & operates 18 PCC cars for regular service.



Terms & Conditions: Equipment available only to end users.

A Leader in Wheels & Maintenance Equipment for Transit, Rail & Mining/Industrial Applications

In 1920, Penn Machine Company (PMC) began as a coal company and pioneered the manufacture of quality replacement parts for coal mining equipment. Over the years, the company has grown to become a major supplier of heavy-duty OEM and aftermarket components for transit, railroad, mining, steel, construction, and general industrial applications. Our business is domestic and international in scope. Our capabilities and experience combine to provide a wide range of quality manufactured products and services. Penn Machine is comprised of three market-focused stand-alone business units: Transit, Locomotive, and Industrial/Mining, with operations in Johnstown and Blairsville, PA. Penn Machine Company is part of Marmon Holdings, Inc., a global organization of manufacturers owned by Berkshire Hathaway Inc.



American Gear Manufacturers Association



Quality System Registrar



PENN MACHINE COMPANY LLC

Headquarters

310 Innovation Drive
Johnstown, PA 15905

106 Station Street
Blairsville, PA 15717



A Marmon | Berkshire Hathaway Company